



TRANS-MINIATS AUTOMATIC TRANSFER SWITCH

1. Introduction

1.1 General Specifications

The unit provides the mains voltage monitoring and automatic transfer switching. In the event of a mains voltage failure, the remote start relay output is energized and the unit automatically transfers the load from the mains to the generator. Both automatic and manual control is possible. A test mode is also available which allows the generator to be run without taking the load.

The unit is extensively programmable through the front panel, with password protection on two levels. Operational parameters can also be monitored and controlled from a PC via a built-in RS-232 communication port.

The unit monitors generator operation and gives warning of any faults that are detected. If a fault is detected, the unit shuts down the engine and shows the failure message on the LCD display.

1.2 Warranty

EMKO Elektronik warrants that the equipment delivered is free from defects in material and workmanship. This warranty is provided for a period of two years. The warranty period starts from the delivery date. This warranty is in force if duty and responsibilities which are determined in warranty document and instruction manual performs by the customer completely.

1.3 Maintenance

Repairs should only be performed by trained and specialized personnel. Cut power to the device before accessing internal parts.

Do not clean the case with hydrocarbon-based solvents (Petrol, Trichlorethylene etc.). Use of these solvents can reduce the mechanical reliability of the device. Use a cloth dampened in ethyl alcohol or water to clean the external plastic case.

2. Installation



Before beginning installation of this product, please read the instruction manual and warnings below carefully.

A visual inspection of this product for possible damage occurred during shipment is recommended before installation. It is your responsibility to ensure that qualified mechanical and electrical technicians install this product.

If there is danger of serious accident resulting from a failure or defect in this unit, power off the system and separate the electrical connection of the device from the system.

Keep the power off until all of the wiring is completed so that electric shock and trouble with the unit can be prevented.

2.1 Unit Configuration

The unit can be programmed using the buttons and LCD display on the front panel or PC Software.

2.2 Panel Mounting

The unit is designed for panel mounting. Fixing is by two screw fixings.

1- Insert the unit in the panel cut-out from the front.

2- Insert the fixings in the slotted at the corners of the unit and tighten the fixing screws to secure the unit against the panel.



During the equipment is putted in hole on the metal panel while mechanical installation some metal burrs can cause injury on hands, you must be careful.

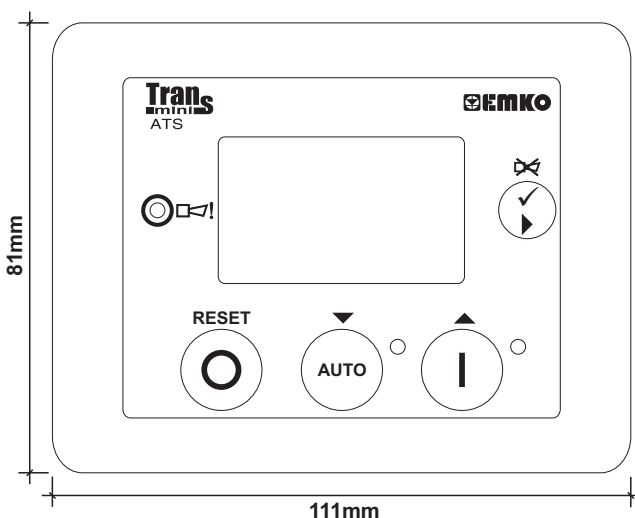

Figure 2.1 Front View

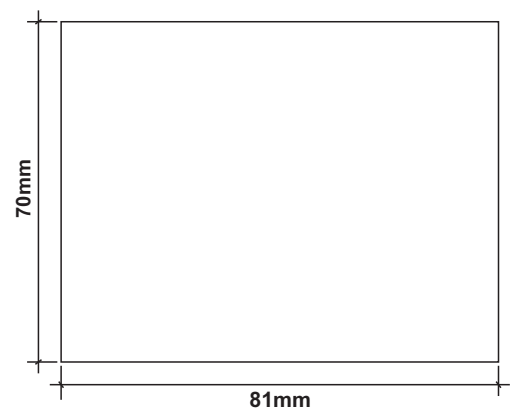
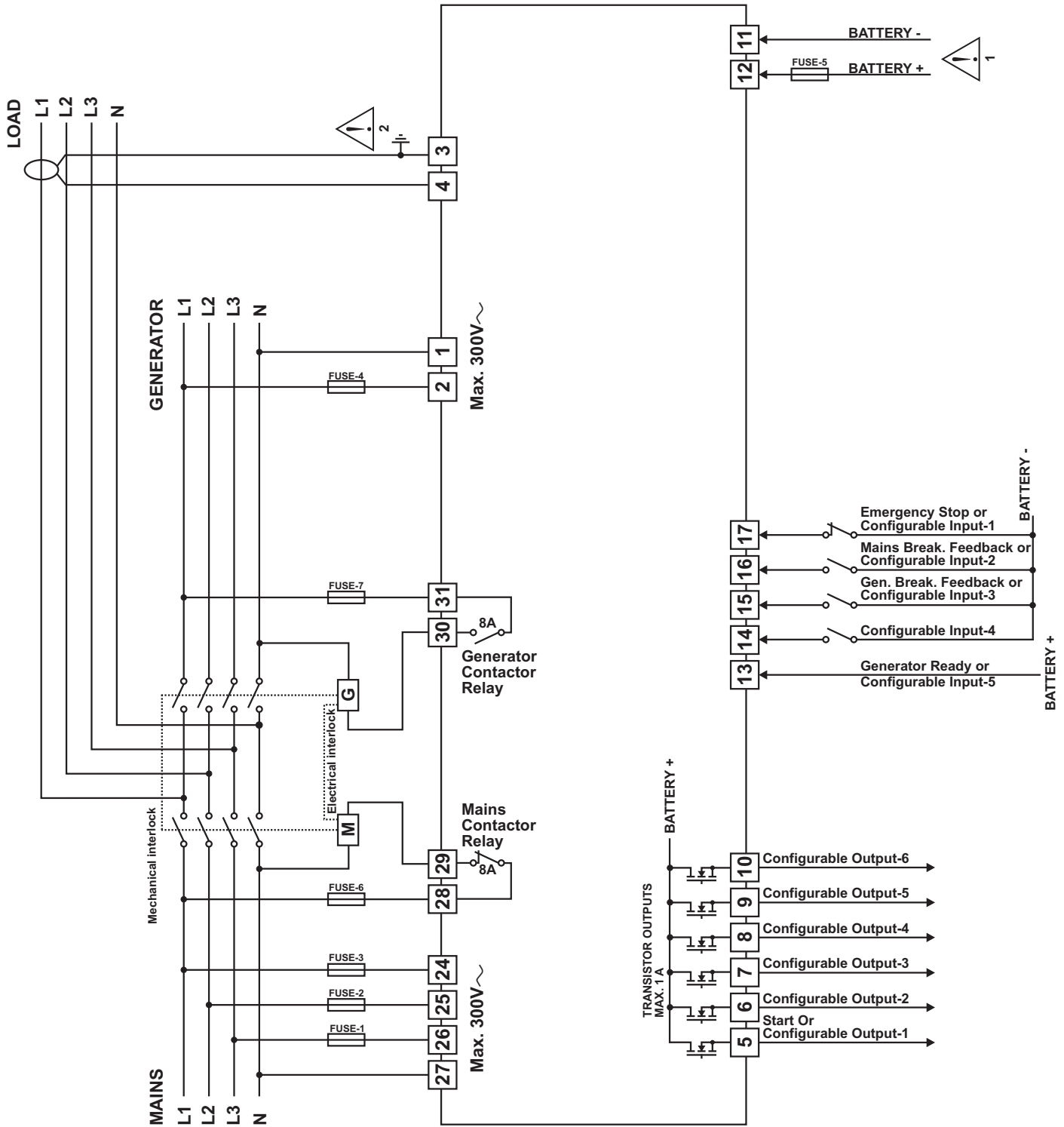

Figure 2.2 Panel Cut-Out

2.3 Electrical Connection

TRANS-MINIATS three phase connections schematic



FUSE-1, FUSE-2, FUSE-3, FUSE-4 2A.T
 FUSE-5 8A.T
 FUSE-6, FUSE-7 8A.T



- 1- Connect the unit as shown in the appropriate diagram. Be sure to connect the battery supply the right way round and battery negative should be grounded.
- 2- Current transformers secondary should be grounded.

3. Changing And Saving Parameters Values

Operation Screen

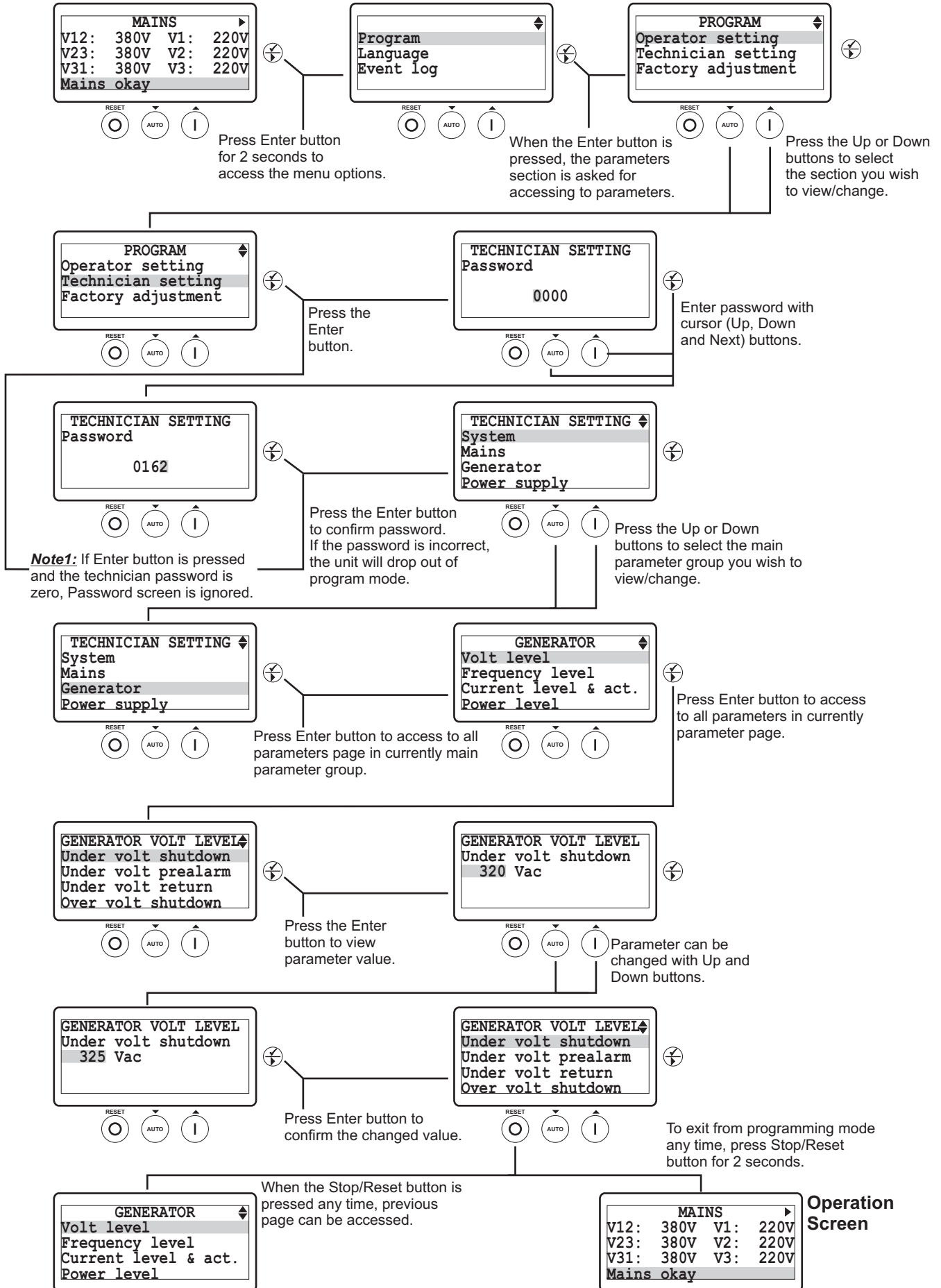

4. Parameters

4.1 Operator Parameters

4.1.1 Mains

MAINS VOLT LEVEL (<i>Mains->Volt level</i>)		Min	Max	Default	Unit
Under volt trip	Mains Under Voltage	60	600	320	V~
Under volt reset	Mains Under Voltage Return	60	600	340	V~
Over volt trip	Mains Over Voltage	60	600	440	V~
Over volt reset	Mains Over Voltage Return	60	600	420	V~

MAINS FREQ. LEVEL (<i>Mains->Frequency level</i>)		Min	Max	Default	Unit
Under freq trip	Mains Under Frequency	20.0	75.0	45.0	Hz
Under freq reset	Mains Under Frequency Return	20.0	75.0	48.0	Hz
Over freq trip	Mains Over Frequency	20.0	75.0	55.0	Hz
Over freq reset	Mains Over Frequency Return	20.0	75.0	52.0	Hz

4.1.2 Generator

GENERATOR VOLT LEVEL (<i>Generator->Volt level</i>)		Min	Max	Default	Unit
Under volt shutdown	Generator Under Voltage Shutdown	60(dis)	600	320	V~
Under volt prealarm	Generator Under Voltage Pre-Alarm	60(dis)	600	340	V~
Under volt reset	Generator Under Voltage Pre-Alarm Return	60	600	350	V~
Over volt shutdown	Generator Over Voltage Shutdown	60	600	440	V~
Over volt prealarm	Generator Over Voltage Pre-Alarm	60(dis)	600	420	V~
Over volt reset	Generator Over Voltage Pre-Alarm Return	60	600	400	V~
Shutdown delay time	Generator Voltage Shutdown Delay Time	0.0	10.0	1.0	Sec

GENERATOR FREQ LEVEL (<i>Generator->Frequency level</i>)		Min	Max	Default	Unit
Under freq shutdown	Generator Under Frequency Shutdown	30.0(dis)	75.0	43.0	Hz
Under freq prealarm	Generator Under Frequency Pre-Alarm	30.0(dis)	75.0	45.0	Hz
Under freq reset	Generator Under Frequency Pre-Alarm Return	30.0	75.0	46.0	Hz
Over freq shutdown	Generator Over Frequency Shutdown	30.0(dis)	75.0	58.0	Hz
Over freq prealarm	Generator Over Frequency Pre-Alarm	30.0(dis)	75.0	55.0	Hz
Over freq reset	Generator Over Frequency Pre-Alarm Return	30.0	75.0	54.0	Hz
Shutdown delay time	Generator Frequency Shutdown Delay Time	0.0	10.0	1.0	Sec

GENERATOR CUR LEVEL (<i>Generator->Current level</i>)		Min	Max	Default	Unit
Under cur. set	Generator Under Current Set	0	9999	1	A~
Under cur. prealarm	Generator Under Current Pre-Alarm	0(dis)	9999	dis	A~
Under cur. reset	Generator Under Current Pre-Alarm Return	0	9999	5	A~
Over cur. set	Generator Over Current Set	0	9999	9999	A~
Over cur. prealarm	Generator Over Current Pre-Alarm	0(dis)	9999	9990	A~
Over cur. reset	Generator Over Current Pre-Alarm Return	0	9999	9980	A~

Note: dis = disable

GEN POWER LEVEL (Generator->Power level)		Min	Max	Default	Unit
Under power shutdown	Generator Under Power Shutdown	0(dis)	9999	dis	kVA
Under power prealarm	Generator Under Power Pre-Alarm	0(dis)	9999	dis	kVA
Under power reset	Generator Under Power Pre-Alarm Return	0	9999	5	kVA
Over power shutdown	Generator Over Power Shutdown	0(dis)	9999	dis	kVA
Over power prealarm	Generator Over Power Pre-Alarm	0(dis)	9999	dis	kVA
Over power reset	Generator Over Power Pre-Alarm Return	0	9999	0	kVA
Shutdown delay time	Generator Power Shutdown Delay Time	0	99	2	Sec
Reverse power set	Reverse Power Set	-9999	0	0	kW

GEN WORKING CALENDAR (Generator->Working calendar)		Min	Max	Default	Unit
Disable/enable select	Working Calendar Disable or Enable	DISBL/ENABL		DISBL	
Start time on monday	Working Calendar Work Start Time on Monday	0.00	23.59	0.00	H.Min
Stop time on monday	Working Calendar Work Stop Time on Monday	0.00	23.59	23.59	H.Min
Start time on tues.	Working Calendar Work Start Time on Tuesday	0.00	23.59	0.00	H.Min
Stop time on tuesday	Working Calendar Work Stop Time on Tuesday	0.00	23.59	23.59	H.Min
Start time on wednes.	Working Calendar Work Start Time on Wednesday	0.00	23.59	0.00	H.Min
Stop time on wednes.	Working Calendar Work Stop Time on Wednesday	0.00	23.59	23.59	H.Min
Start time on thurs.	Working Calendar Work Start Time on Thursday	0.00	23.59	0.00	H.Min
Stop time on thursday	Working Calendar Work Stop Time on Thursday	0.00	23.59	23.59	H.Min
Start time on friday	Working Calendar Work Start Time on Friday	0.00	23.59	0.00	H.Min
Stop time on friday	Working Calendar Work Stop Time on Friday	0.00	23.59	23.59	H.Min
Start time on satur.	Working Calendar Work Start Time on Saturday	0.00	23.59	0.00	H.Min
Stop time on saturday	Working Calendar Work Stop Time on Saturday	0.00	23.59	23.59	H.Min
Start time on sunday	Working Calendar Work Start Time on Sunday	0.00	23.59	0.00	H.Min
Stop time on sunday	Working Calendar Work Stop Time on Sunday	0.00	23.59	23.59	H.Min

4.2 Technician Parameters

4.2.1 System

SYSTEM NETWORK (System->Network)		Min	Max	Default	Unit
CT ratio	Current Transformer Ratio	5	9999	100	
PT ratio	Voltage Transformer Ratio	1	50	1	
Type of AC system	Select AC system; 0- 1 Phase 2 Wire 1- 3 Phase 4 Wire 2- 2 Phase 3 Wire L1-L2 3- 2 Phase 3 Wire L1-L3	0	3	1	
Generator kVA rating	Generator kVA rating set	0	9999	300	kVA

Note-1 : dis = disable

BREAKERS (System->Breakers)		Min	Max	Default	Unit
Type of Breaker	Hardware Breaker Selection	0	2	0	
Gen.brk.cls.contact	Gen Close Breaker Contact Type	NO / NC		0	
Gen.brk.cls.relay	Gen Close Breaker Relay Type	NOR / PULS		0	
Gen.brk.cls.time	Gen Close Timer	1	250	5	Sec
Gen.brk.open relay	Gen Open Breaker Relay Type	NOR / PULS		0	
Gen.brk.open time	Gen Open Timer	1	250	5	Sec
Mains.brk.cls.contact	Mains Close Breaker Contact Type	NO / NC		0	
Mains.brk.cls.relay	Mains Close Breaker Relay Type	NOR / PULS		0	
Mains.brk.cls.time	Mains Close Timer	1	250	5	Sec
Mains.brk.open relay	Mains Open Breaker Relay Type	NOR / PULS		0	
Mains.brk.open time	Mains Open Timer	1	250	5	Sec
Break.close puls.time	Breaker Close Pulse Time	0.0	10.0	0.5	Sec
Break.open pulse time	Breaker Open Pulse Time	0.0	10.0	0.5	Sec
Transfer time	Transfer Time	0	250	2	Sec
Spring loading time	Spring Loading Time	1	250	3	Sec
Retry number	Retry Number	1	250	5	

LCD DISPLAY (System->LCD display)		Min	Max	Default	Unit
Language* ¹	Language Selection	ENGLISH/CHINESE		ENGLISH	
Contrast	Digital Contrast	4	9	5	
Auto backlight off	Auto Backlight Off	DISBL/ENABL		DISBL	
Auto scroll time	Auto Scroll Time	0 (dis)	250	0	Sec
Auto scroll number	Auto Scroll Number	1	8	3	
Err. mesg scroll time	Scroll Time For Error Messages	1	250	2	Sec

COMMUNICATION (System->Communication)		Min	Max	Default	Unit
Slave address	Slave Address	1	247	1	
Baud rate	Baud Rate	0	5	3	
	0 - 1200 baud				
	1 - 2400 baud				
	2 - 4800 baud				
	3 - 9600 baud				
	4 - 19200 baud				
Parity	5 - 38400 baud				
	Parity	0	2	0	
	0 - NONE 1 - ODD 2 - EVEN				
Stop bit	Stop Bit (0-> 1 stop bit,1-> 2 stop bit)	0	1	0	

Note: *1 = Selectable value of this parameter is "ENGLISH/TURKISH" at Trans-MiniATS (TR) devices.
NO / NC : Normally Open / Normally Close
NOR / PULS : Normal / Pulse
dis = disable

DATE & TIME SET (System->Date & time set)		Min	Max	Default	Unit
Year	Year	0	99		
Month	Month	1	12		
Day	Date	1	31		
Week	Day of week	1	7		
Hour	Hour	0	23		
Minute	Minute	0	59		
Second	Second	0	59		

DEFAULT SETTINGS (System->Default settings)		Min	Max	Default	Unit
Save setting to def.	Save setting to default	YES / NO		NO	
Reset default sets	Reset default sets	YES / NO		NO	
Reset factory sets	Reset factory sets	YES / NO		NO	

PASSWORD SETTINGS (System->Password settings)		Min	Max	Default	Unit
Operator password	Operator Password	0	9999	0	
Technician password	Technician Password	0	9999	0	

4.2.2 Mains

MAINS VOLT LEVEL (Mains->Volt level)		Min	Max	Default	Unit
Under volt trip	Mains Under Voltage	60	600	320	V~
Under volt reset	Mains Under Voltage Return	60	600	340	V~
Over volt trip	Mains Over Voltage	60	600	440	V~
Over volt reset	Mains Over Voltage Return	60	600	420	V~

MAINS FREQ. LEVEL (Mains->Frequency level)		Min	Max	Default	Unit
Under freq trip	Mains Under Frequency	20.0	75.0	45.0	Hz
Under freq reset	Mains Under Frequency Return	20.0	75.0	48.0	Hz
Over freq trip	Mains Over Frequency	20.0	75.0	55.0	Hz
Over freq reset	Mains Over Frequency Return	20.0	75.0	52.0	Hz

MAINS ACTIONS (Mains->Actions)		Min	Max	Default	Unit
Mains failure detect	Mains Failure Detection En/Dis	ENABL/DISBL		ENABL	
Mains fail.stop mode	Look Mains Failure at Stop Mode En/Dis	ENABL/DISBL		ENABL	
Always return delay	Always Look Mains Return Delay	ENABL/DISBL		DISBL	

4.2.3 Generator

GENERATOR VOLT LEVEL (Generator->Volt level)		Min	Max	Default	Unit
Under volt shutdown	Generator Under Voltage Shutdown	60(dis)	600	320	V~
Under volt prealarm	Generator Under Voltage Pre-Alarm	60(dis)	600	340	V~
Under volt reset	Generator Under Voltage Pre-Alarm Return	60	600	350	V~
Over volt shutdown	Generator Over Voltage Shutdown	60	600	440	V~
Over volt prealarm	Generator Over Voltage Pre-Alarm	60(dis)	600	420	V~
Over volt reset	Generator Over Voltage Pre-Alarm Return	60	600	400	V~
Shutdown delay time	Generator Voltage Shutdown Delay Time	0.0	10.0	1.0	Sec

Note: dis = disable

GENERATOR FREQ LEVEL (<i>Generator->Frequency level</i>)		Min	Max	Default	Unit
Under freq shutdown	Generator Under Frequency Shutdown	30.0(dis)	75.0	43.0	Hz
Under freq prealarm	Generator Under Frequency Pre-Alarm	30.0(dis)	75.0	45.0	Hz
Under freq reset	Generator Under Frequency Pre-Alarm Return	30.0	75.0	46.0	Hz
Over freq shutdown	Generator Over Frequency Shutdown	30.0(dis)	75.0	58.0	Hz
Over freq prealarm	Generator Over Frequency Pre-Alarm	30.0(dis)	75.0	55.0	Hz
Over freq reset	Generator Over Frequency Pre-Alarm Return	30.0	75.0	54.0	Hz
Shutdown delay time	Generator Frequency Shutdown Delay Time	0.0	10.0	1.0	Sec

GEN CUR LEVEL & ACT (<i>Generator->Current level & act.</i>)		Min	Max	Default	Unit
Under cur. set	Generator Under Current Set	0	9999	1	A~
Under cur. prealarm	Generator Under Current Pre-Alarm	0(dis)	9999	dis	A~
Under cur. reset	Generator Under Current Pre-Alarm Return	0	9999	5	A~
Under cur. act.	Generator Under Current Actions 0 - Disable 1 - Warning (Alarm Only, No Shutdown) 2 - Electrical Trip (Alarm/Off Load Generator Followed By Shutdown After Cooling) 3 - Shutdown (Alarm And Shutdown)	0(dis)	3	dis	
Under act. delay time	Generator Under Current Actions Delay Time	0	99	2	Sec
Over cur. set	Generator Over Current Set	0	9999	9999	A~
Over cur. prealarm	Generator Over Current Pre-Alarm	0(dis)	9999	9990	A~
Over cur. reset	Generator Over Current Pre-Alarm Return	0	9999	9980	A~
Over cur. act.	Generator Over Current Actions 0 - Disable 1 - Warning (Alarm Only, No Shutdown) 2 - Electrical Trip (Alarm/Off Load Generator Followed By Shutdown After Cooling) 3 - Shutdown (Alarm And Shutdown)	0(dis)	3	dis	
Over act. delay time	Generator Over Current Actions Delay Time	0	99	2	Sec
Short circuit cur.	Generator Short Circuit Current Set	0	9999	9999	A~

GEN POWER LEVEL (<i>Generator->Power level</i>)		Min	Max	Default	Unit
Under power shutdown	Generator Under Power Shutdown	0(dis)	9999	dis	kVA
Under power prealarm	Generator Under Power Pre-Alarm	0(dis)	9999	dis	kVA
Under power reset	Generator Under Power Pre-Alarm Return	0	9999	5	kVA
Over power shutdown	Generator Over Power Shutdown	0(dis)	9999	dis	kVA
Over power prealarm	Generator Over Power Pre-Alarm	0(dis)	9999	dis	kVA
Over power reset	Generator Over Power Pre-Alarm Return	0	9999	0	kVA
Shutdown delay time	Generator Power Shutdown Delay Time	0	99	2	Sec
Reverse power set	Reverse Power Set	-9999	0	0	kW
Reverse power act.	Reverse Power Actions 0 - Disable 1 - Warning (Alarm Only, No Shutdown) 2 - Electrical Trip (Alarm/Off Load Generator Followed By Shutdown After Cooling) 3 - Shutdown (Alarm And Shutdown)	0(dis)	3	0(dis)	
Rv.pow.act.delay time	Reverse Power Action Delay Time	0	99	2	Sec

Note: dis = disable

GEN WORKING CALENDAR (<i>Generator->Working calendar</i>)		Min	Max	Default	Unit
Disable/enable select	Working Calendar Disable or Enable	DISBL/ENABL		DISBL	
Start time on monday	Working Calendar Work Start Time on Monday	0.00	23.59	0.00	H.Min
Stop time on monday	Working Calendar Work Stop Time on Monday	0.00	23.59	23.59	H.Min
Start time on tues.	Working Calendar Work Start Time on Tuesday	0.00	23.59	0.00	H.Min
Stop time on tuesday	Working Calendar Work Stop Time on Tuesday	0.00	23.59	23.59	H.Min
Start time on wednes.	Working Calendar Work Start Time on Wednesday	0.00	23.59	0.00	H.Min
Stop time on wednes.	Working Calendar Work Stop Time on Wednesday	0.00	23.59	23.59	H.Min
Start time on thurs.	Working Calendar Work Start Time on Thursday	0.00	23.59	0.00	H.Min
Stop time on thursday	Working Calendar Work Stop Time on Thursday	0.00	23.59	23.59	H.Min
Start time on friday	Working Calendar Work Start Time on Friday	0.00	23.59	0.00	H.Min
Stop time on friday	Working Calendar Work Stop Time on Friday	0.00	23.59	23.59	H.Min
Start time on satur.	Working Calendar Work Start Time on Saturday	0.00	23.59	0.00	H.Min
Stop time on saturday	Working Calendar Work Stop Time on Saturday	0.00	23.59	23.59	H.Min
Start time on sunday	Working Calendar Work Start Time on Sunday	0.00	23.59	0.00	H.Min
Stop time on sunday	Working Calendar Work Stop Time on Sunday	0.00	23.59	23.59	H.Min

GENERATOR GENERAL (<i>Generator->General</i>)		Min	Max	Default	Unit
Sens.option gen.freq	Sensing Options Generator Frq En/Dis	ENABL/DISBL		ENABL	
All warning are latch	All Warnings Are Latched En/Dis	ENABL/DISBL		DISBL	

4.2.4 Power Supply

POWER SUPPLY BATTERY (<i>Power Supply->Battery</i>)		Min	Max	Default	Unit
Under volt	Battery Undervolts Warning	6.0(dis)	30.0	10.0	V $\underline{\underline{=}}$
Under volt reset	Battery Undervolts Warning Return	6.0	30.0	10.5	V $\underline{\underline{=}}$
Under volt delay	Battery Undervolts Volts Delay	0.0	9.9	1.0	Sec
Over volt	Battery Overvolts Warning	6.0(dis)	30.0	30.0	V $\underline{\underline{=}}$
Over volt reset	Battery Overvolts Warning Return	6.0	30.0	29.5	V $\underline{\underline{=}}$
Over volt delay	Battery Overvolts Delay	0.0	9.9	1.0	Sec

4.2.5 Engine

LOAD TEST (<i>Engine->Load test</i>)		Min	Max	Default	Unit
Disable/enable select	Disable, No Load or On Load Selection	0-DISABLE 1-NO LOAD 2-ON LOAD		1-NO LOAD	

EXERCISE (<i>Engine->Exercise</i>)		Min	Max	Default	Unit
Time of period	Generator exercise working period on related day	0(dis)	99	dis	Min
Week	Generator exercise working day of week	1	7	1	
Start time	Generator exercise work start time on related day	0.0	23.59	0.00	H.Min

ENGINE GENERAL (<i>Engine->General</i>)		Min	Max	Default	Unit
Engine running volt	Engine running voltage	60(dis)	600	300	V \sim
Engine running freq.	Engine running frequency	25.0	75.0	30.0	Hz

Note: dis = disable

4.2.6 Inputs

CONF. INPUT-X (Inputs->Conf. input-x)		Min	Max	Default	Unit
Dis,user conf.or list	0- Disable 1- User Configured 2- Select From List	0(dis)	2	in1=2 in2, 3=0 in4=0 in5=2	
Polarity	0- Normally Open (Close To Activate) 1- Normally Close (Open To Activate)	0	1	in1=1 in2, 3=0 in4, 5=0	
Indication	If User Configured 0- Status 1- Warning Non-Latching 2- Warning Latching 3- Electrical Trip 4- Shutdown	0	4	in1=0 in2=0 In3=0 in4=0 In5=0	
Activation	If User Configured 0- Active From Starting 1- Active From Safety On 2- Always Active	0	2	in1=2 in2=2 in3=2 in4=2 in5=2	
Select from list	If Select From List 0-Remote Start On Load 1-Remote Start Off Load 2-Auxiliary Mains Fail 3-Reserved 4-Reserved 5-Reserved 6-Simulate Auto Button 7-Simulate Test Button 8-Reserved 9-Simulate Start Button 10-Simulate Stop Button 11-Generator Closed Auxiliary 12-Generator Load Inhibit 13-Mains Closed Auxiliary 14-Mains Load Inhibit 15-Auto Restore Inhibit 16-Auto Start Inhibit 17-Panel Lock 18-Scheduled Runs(Exercise) Inhibited 19-Reserved 20-Reserved 21-Reserved 22-Remote Inhibit 23-Engine Running 24-Generator Ready 25-Emergency Stop	0	25	in1=25 in2=13 in3=11 in4=23 in5=24	
Active delay	Input active delay	0	250	in1=0 in2, 3=1 in4, 5=1	Sec

Note-1 : x = 1(input-1), 2(input-2), 3(input-3), 4(input-4) or 5(input-5)

Note-2 : dis = disable

4.2.7 Outputs

CONF. OUTPUT-1 (<i>Outputs->Conf. output-1</i>)		Min	Max	Default	Unit
Polarity	0- Normally Open (Close To Activate) 1- Normally Close (Open To Activate)	0	1	0	
Function	0-NOT USED 1-AIR FLAP CONTROL 2-ALARM RESET 3-AUDIBLE ALARM 4-AUTO START INHIBIT 5-AUXILIARY MAINS FAILURE 6-BATTERY HIGH VOLTAGE 7-BATTERY LOW VOLTAGE 8-CALLING FOR SCHEDULED RUN(EXERCISE) 9-RESERVED 10-RESERVED 11-RESERVED 12-COMMON ALARM 13-COMMON ELECTRICAL TRIP ALARM 14-COMMON SHUTDOWN ALARM 15-COMMON WARNING ALARM 16-RESERVED 17-RESERVED 18-RESERVED 19-RESERVED 20-COOLING DOWN TIMER IN PROGRESS 21-RESERVED 22-DELAYED ALARMS ACTIVE 23-DIGITAL INPUT1 ALARM 24-DIGITAL INPUT2 ALARM 25-DIGITAL INPUT3 ALARM 26-DIGITAL INPUT4 ALARM 27-DIGITAL INPUT5 ALARM 28-RESERVED 29-RESERVED 30-RESERVED 31-RESERVED 32-RESERVED 33-RESERVED 34-RESERVED 35-RESERVED 36-RESERVED 37-RESERVED 38-RESERVED 39-EMERGENCY STOP 40-FAIL TO START ALARM 41-FAIL TO STOP ALARM 42-RESERVED 43-RESERVED 44-RESERVED 45-GENERATOR AT REST 46-GENERATOR AVAILABLE 47-GENERATOR CLOSED AUXILIARY 48-GENERATOR FAILED TO CLOSE 49-GENERATOR FAILED TO OPEN 50-GENERATOR HIGH FREQUENCY PRE-ALARM 51-GENERATOR HIGH FREQUENCY SHUTDOWN 52-GENERATOR HIGH VOLTAGE PRE-ALARM 53-GENERATOR HIGH VOLTAGE SHUTDOWN 54-GENERATOR LOAD INHIBIT 55-GENERATOR LOW FREQUENCY PRE-ALARM 56-GENERATOR LOW FREQUENCY SHUTDOWN 57-GENERATOR LOW VOLTAGE PRE-ALARM 58-GENERATOR LOW VOLTAGE SHUTDOWN 59-GENERATOR STOPPING 60-GENERATOR OPEN BREAKER 61-HORN OUTPUT LATCHED 62-HORN OUTPUT PULSED 63-LAMP TEST 64-RESERVED 65-RESERVED 66-RESERVED 67-RESERVED 68-MAINS CLOSED AUXILIARY 69-MAINS FAILED TO CLOSE 70-MAINS FAILED TO OPEN 71-MAINS FAILURE 72-MAINS HIGH FREQUENCY 73-MAINS HIGH VOLTAGE 74-MAINS LOAD INHIBIT 75-MAINS LOW FREQUENCY 76-MAINS LOW VOLTAGE 77-MAINS OPEN BREAKER 78-NO LOADING COMMAND 79-RESERVED 80-RESERVED 81-RESERVED 82-RESERVED 83-OVER CURRENT PRE-ALARM 84-OVER CURRENT 85-OVER POWER PRE-ALARM 86-OVER POWER SHUTDOWN 87-RESERVED 88-RESERVED 89-PANEL LOCK 90-RESERVED 91-RESERVED 92-RESERVED 93-RESERVED 94-REMOTE START PRESENT 95-RESERVED 96-SHORT CIRCUIT 97-RESERVED 98-RESERVED 99-STARTING ALARMS ARMED 100-RESERVED 101-SYSTEM IN AUTO MODE 102-SYSTEM IN MANUAL MODE 103-SYSTEM IN STOP MODE 104-SYSTEM IN TEST MODE 105-UNDER CURRENT PRE-ALARM 106-UNDER CURRENT 107-UNDER POWER PRE-ALARM 108-UNDER POWER SHUTDOWN 109-RESERVED 110-RESERVED 111-WAITING FOR GENERATOR 112-REVERSE POWER 113-LOAD SUPPLY FROM GENERATOR 114-LOAD SUPPLY FROM MAINS 115-RESERVED 116-RESERVED 117-RESERVED 118-RESERVED 119-RESERVED 120-RESERVED 121-RESERVED 122-REMOTE CONTROL ACTIVE	0	122	94	

CONF. OUTPUT-2 (Outputs->Conf. output-2)		Min	Max	Default	Unit
Polarity	0- Normally Open (Close To Activate) 1- Normally Close (Open To Activate)	0	1	0	
Function	The same as Configurable Output-1 options	0	122	21	

CONF. OUTPUT-3 (Outputs->Conf. output-3)		Min	Max	Default	Unit
Polarity	0- Normally Open (Close To Activate) 1- Normally Close (Open To Activate)	0	1	0	
Function	The same as Configurable Output-1 options	0	122	62	

CONF. OUTPUT-4 (Outputs->Conf. output-4)		Min	Max	Default	Unit
Polarity	0- Normally Open (Close To Activate) 1- Normally Close (Open To Activate)	0	1	0	
Function	The same as Configurable Output-1 options	0	122	12	

CONF. OUTPUT-5 (Outputs->Conf. output-5)		Min	Max	Default	Unit
Polarity	0- Normally Open (Close To Activate) 1- Normally Close (Open To Activate)	0	1	0	
Function	The same as Configurable Output-1 options	0	122	13	

CONF. OUTPUT-6 (Outputs->Conf. output-6)		Min	Max	Default	Unit
Polarity	0- Normally Open (Close To Activate) 1- Normally Close (Open To Activate)	0	1	0	
Function	The same as Configurable Output-1 options	0	122	14	

4.2.8 Timers

START TIMERS (Timers->Start timers)		Min	Max	Default	Unit
Mains transient delay	Mains Transient Delay	0.0	20.0	2.0	Sec
Mains fail start delay	Mains Fail Start Delay	0	9999	0	Sec
Remote start delay	Remote Start Delay	0	3600	4	Sec
Gen. fail delay	Generator Fail Delay	0	250	45	Sec
Safety on delay	Safety On Delay	0	99	5	Sec
Warming up time	Warmup Time	0	250	3	Sec
Horn duration	Horn Duration	0 (dis)	999	60	Sec

STOPPING TIMERS (Timers->Stopping timers)		Min	Max	Default	Unit
Mains return delay	Mains Return Delay	0	3600	5	Sec
Remote stop delay	Remote Stop Delay	0	250	4	Sec
Cooling time	Cooling Time	0 (dis)	3600	60	Sec
Fail to stop delay	Fail To Stop Time	15	999	30	Sec

Note: dis = disable cont = continuous

4.2.9 User Adjustment

MAINS VOLTAGE OFFSET (User adjustment->Mains voltage offset)		Min	Max	Default	Unit
Mains V1 offset	Mains V1 Offset	-20	20	0	V \sim
Mains V2 offset	Mains V2 Offset	-20	20	0	V \sim
Mains V3 offset	Mains V3 Offset	-20	20	0	V \sim

GEN. VOLTAGE OFFSET (User adjustment->Gen. voltage offset)		Min	Max	Default	Unit
Gen. V1 offset	Generator V1 Offset	-20	20	0	V \sim

CURRENT OFFSET (User adjustment->Current offset)		Min	Max	Default	Unit
Current I1 offset	Current I1 Offset	-20	20	0	A \sim

BATTERY OFFSET (User adjustment->Battery Offset)		Min	Max	Default	Unit
Batt.volt offset	Battery Voltage Offset	-5.0	5.0	0	V ---

5. Specifications

Equipment use	: Electrical control equipment for generating sets.
Housing & Mounting	: 111 mm x 81 mm x 61 mm. (including connectors). Plastic housing for panel mounting.
Panel Cut-Out	: 81mm x 70mm.
Protection	: IP65 at front panel.
Weight	: Approximately 0,3 Kg.
Environmental rating	: Standard, indoor at an altitude of less than 2000 meters with non-condensing humidity.
Operating/Storage Temperature	: -20°C to +70°C / -30°C to +80°C
Operating/Storage Humidity	: 90 % max. (non-condensing)
Installation Over Volt. Category	: II Appliances, portable equipment
Pollution Degree	: II, Normal office or workplace, non conductive pollution
Mode of Operation	: Continuous.
DC Battery Supply Voltage	: 8 to 32 V --- . Max. operating current is 360 mA.
Cranking Dropouts	: Battery voltage can be "0" VDC for max. 50 ms during cranking (battery voltage should be at least nominal voltage before cranking).
Battery Voltage Measurement	: 8 to 32 V --- , accuracy: 1 % FS, resolution: 0,1 V
Mains Voltage Measurement	: 3 to 300 VAC Ph-N, 5 to 99.9 Hz. Accuracy: 1 % FS, Resolution: 1 V.
Mains Frequency	: 5 to 99.9Hz (min. 20 VAC Ph-N) Accuracy: 0,25 % FS, Resolution: 0,1 Hz.
Generator Voltage Measurement	: 3 to 300 VAC Ph-N, 5 to 99.9 Hz. Accuracy: 1 % FS, Resolution: 1 V.
Generator Frequency	: 5 to 99.9Hz (min. 20 VAC Ph-N) Accuracy: 0,25 % FS, Resolution: 0,1 Hz.
CT secondary	: 5A.
Communication interface	: RS-232
Relay Outputs	: Generator contactor relay output 8A@250V \sim Mains contactor relay output 8A@250V \sim
Transistor Outputs	: Start or Configurable output-1 1A at DC supply voltage Configurable output-2 1A at DC supply voltage Configurable output-3 1A at DC supply voltage Configurable output-4 1A at DC supply voltage Configurable output-5 1A at DC supply voltage Configurable output-6 1A at DC supply voltage All transistor outputs supplied from DC supply terminal 12
Approvals	: EAC , CE

6. Other Informations

Manufacturer Information:

Emko Elektronik Sanayi ve Ticaret A.Ş.
Demirtaş Organize Sanayi Bölgesi Karanfil Sk. No:6 16369
BURSA/TURKEY

Phone : +90 224 261 1900
Fax : +90 224 261 1912

Repair and maintenance service information:

Emko Elektronik Sanayi ve Ticaret A.Ş.
Demirtaş Organize Sanayi Bölgesi Karanfil Sk. No:6 16369
BURSA/TURKEY
Phone : +90 224 261 1900
Fax : +90 224 261 1912

7. Order Information

Trans-MiniATS : Automatic Transfer Switch

Note: Devices have time clock. If real time clock is needed, "RTC" expression must be added to end of order code.
Example: Trans-MiniATS.RTC



<https://www.emkoelektronik.com.tr/en/products/trans-miniats>



Thank you very much for your preference to use Emko Elektronik products, please visit our web page to download detailed user manual.

www.emkoelektronik.com.tr